

SCREW AIR COMPRESSOR CONTROLLER
MAM-KY02SVF (B) - (VF-III)
(Monitor-200)

USER
MANUAL

Shenzhen Plot Electronic Co., Ltd

Address: 4-5F,5 Bldg,Highstar Industry Park,Gangtou Community,
Bantian,Longgang District,Shenzhen City, China

Telephone: (+86 0755) 83173599 / 83172822 Postal code: 518129

Fax: (+86 0755) 83172966

E-mail: plt@pltsz.com

Web site: www.pltsz.com

VOTE OF THANKS

Thank you for your trustworthy and select of PLOT air compressor controller !

Shenzhen Plot Electronic Co., Ltd specializes on the manufacture and R&D of air compressor controller. We are devoted to win customer trust through our high quality products and service.

We try our best to ensure the completeness and correctness of the manual, but PLOT Company shall reserve the rights for continuous research and improvement on its products and assume no obligation for the modification and improvement on the previously delivered products. The design of products is subject to the change without notice.

Please feel free to contact our after-sale service center if you encounter any problem with our product.

You are always welcome to make suggestions and advices!



NOTICE



Please read all the operation manual before operating the set and keep this manual for further reference.



Installation of MAM—KY compressor controller can be performed only by professional technicians.**



Installation position shall be considered carefully in order to ensure good ventilation and reduce electromagnetic interference.



Wiring shall be performed respectively according to regulations for heavy and weak current to reduce electromagnetic interference.



RC snubber must be connected to the two terminals of coil (such as AC contactor ,valve, etc),which are controlled by relay output.



Port connection shall be inspected carefully before power on.



Correct ground connection (the third ground)can help increase product capacity of resisting signal interference.



Set rated current of motor: the max current of motor/1.2.

Features:

- Chinese / English display.
- Integrate PID calculation and control , adjust load rate automatically based on air pressure and inverter operation frequency
- current open phase, current overload, current unbalance protection for motor
- On-off control and running control of motor.
- Prevention for air compressor reversal
- Temperature measurement , control and protection
- High integration , high reliability ,high cost performance.
- Remote control/Local control.
- Block mode/Independent mode.
- RS-485 communication function, one for inverter and the other for block control or external communication

Contents

1, Basic Operation	5
1.1, Button Explanation	5
1.2, Status Display and Operation	6
2, Controller Function and Technical Parameter	12
3, Model and Specification	13
3.2, Power specification sheet for corresponding motor.	14
4, Inverter Communication	14
4.1, Communication Function	14
4.2, Communication Set	14
4.3, Inverter Upgrade Explanation	14
5, Installation	16
5.1, Mechanical Installation	16
5.2, Electrical Connections	18
6, Alarm Function	18
6.1, Monitor Indication	18
6.2, Controller indicator	19
7, Controller Protection	20
8, Troubleshooting	20
8.1, This Fault Review	21
8.2, Common Failures and Causes:	21
9, Schematic Diagram:	23

1, Basic Operation

1.1, Button Explanation



Picture 1

I—Start Button:

- 1, When compressor is at stop status, press this button to start the compressor.
- 2, When compressor is set as master (No.1) in block mode ,press this button to start the compressor and activate block mode function at the same time.

O—Stop Button:

- 1, When the compressor is at running status, press this button to stop the compressor;
- 2, When compressor is set as master (No.1) in block mode ,press this button to stop compressor and block mode function as well.

↕—Load / unload Button:

When the compressor is at running status ,press this button to load or unload ;

S—Set Button:

1. When modifying data, press this button after modification to save and confirm the modified data.
2. When the compressor is at password setting status ,press this button to save and confirm the password

↑—Move up button/Increasing button:

- 1, when viewing the menu, press this button to move upward the cursor ;
- 2, When modifying data, press this button to increase the data at current position .

↓——Move down button / Decreasing button:

- 1, When viewing the menu, press this button to move downward the cursor;
- 2, When modifying data, press this button to decrease the data at current position.

→——Shift button /Enter button:

- 1, When modifying data, press this button to move to the next data bit;
- 2, when select menu, press this button to switch to submenu. If no submenu available, the controller will shift to data setting mode.

C——Return button / Reset button:

- 1, When modifying data, press this button to exist data setting mode;
- 2, When viewing the menu, press this button to return to previous-menu;
- 3, When the controller is at failure stop status, long press this button to reset.

1.2, Status Display and Operation

The display screen will show as below after power on::

```
WELCOME

SCREW COMPRESSOR
```

After 5 seconds, the menu will switch as below:

```
DISC T: 20°C   FREQ:50HZ
AIR P: 0.60Mpa  SPEED:1234RPM
LOADING        FAN START
FREQ:123.1KW   VOLT:381V C01
```

Press “↓” to enter into Selection Menu:

```
RUN PARAMETER
CALENDAR
CUSTOMER PARAMETER
FACTORY PARAMETER
```

1.2.1, Operating Parameter and Menu

Press “↓” or “↑” to move the cursor to “RUN PARAMETER”, then press “→” to switch to secondary menu:

```
MOTOR、FAN CURR
VSD PARAMETER
TOTAL RUN TIME
THIS RUN TIME
```

Move the cursor to “MOTOR,FAN CURR”, press “→” to switch to secondary menu:

```
CURR(A): R   S   T
MOTOR:  56.1 56.2 56.0
FAN:    4.1  4.1  4.1
```

Press “RT”, to return to the previous menu or the main menu. If no operation at the current menu for 120 seconds , controller will automatically return to the main menu and turn off the back light simultaneously.

According to above method, use move down “↓”,move up button“↑”, enter button“→”and return button “C” to check TOTAL RUN TIME,THIS RUN TIME,VSD PARAMETER,MAINTENANCE PARA,FAULT RECORD, PROD.DATE、 SERIAL,THIS FAULT and return to previous menu.

1.2.2, Calendar

Check and set time of controller

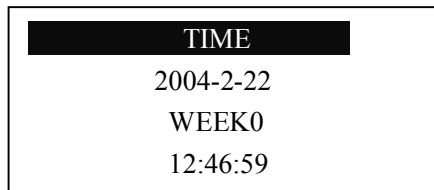

1.2.3, Customer Parameter

A, Customer parameter view and modification

It is not allowed to modify CUSTOMER PARAMETER and FACTORY PARAMETER in running status and STOP DELAY

The check and modification of CUSTOMER PARAMETER is similar with RUN PARAMETER. Take UNLOAD P as example: Move “↓”or“↑”to CUSTOMER PARAMETER and then press “→”to switch to below menu

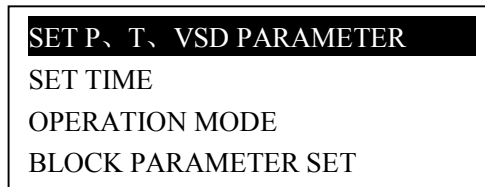

press “→” to switch to below menu

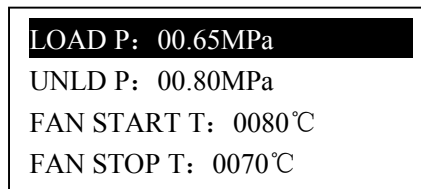

Move the cursor to item LOAD P, then press “→” to switch to the following menu which requires a user password input.



Note: User password can be modified in customer parameter and FACTORY PARAMETER is fixed as _____

In this menu, the first data bit of password starts blinking, press “↓” or “↑” to modify the first bit of password, Press “→” to move the cursor to the next data bit, modify the second data of password in accordance with the above, and modify the third and fourth data of password in sequence. Press “S” to confirm the input data and the menu will switch to the following menu after verification:

LOAD P: 00.65MPa
UNLD P: 00.80MPa
FAN START T: 0080°C
FAN STOP T: 0070°C

“*”in the right up corner indicates that the data is at a setting status

In the menu above, press “→”, the first data of LOAD P starts blinking, user can press “↑” or “↓” to modify the present data in accordance with the above method. Press “→” to move to next data and modify the target data in sequence. When finished, press “S” to confirm and save the data.

B, Customer Parameter Sheet and Function

First menu	Second menu	Preset Data	Function
SET P、T、VSD PARAMETER	LOAD P	00.65MPa	1,In AUTO load mode, compressor will load if pressure is below this set data 2,In STANDBY mode, compressor will start if the pressure is below this set data
	UNLD P	00.80MPa	1,Compressor will unload automatically if air pressure is above this set data 2.This data should be set above LOAD P, also should be set below UNLD P LIM
	FAN START T	0080°C	Fan will start if DISC T is above this set data
	FAN STOP T	0070°C	Fan will stop if DISC T is below this set data
	VSD P	00.70MPa	Set AIR P for VSD compressor to keep running stable, when pressure is fluctuated around this data, controller will adjust operation frequency of inverter to control the pressure close to this data
	MOTOR RAT POWER	022.0KW	Set RATED POWER in order to calculate actual power
	MOTOR RAT SPEED	2600RPM	Set RATED SPEED at 50HZ in order to calculate the actual speed in variable frequency
SET TIME	MOTOR START TIME	0008S	Set the MOTOR START TIME. Record time when motor is activated, controller will not start overload protection during this time to avoid impulse starting current stopping the motor.
	FAN START TIME	0003S	Set the FAN START TIME. Record time when fan is activated, controller will not start overload protection during this time to avoid impulse starting current stopping the fan.
	STAR DELAY TIME	0006S	Interval time from star start to delta start.

	LOAD DELAY TIME	0002S	Unloading in this set time after enter delta running
	STANDBY DELAY	0600S	When unloading continuously, compressor will automatically stop and enter to standby status if over this set time
	STOP DELAY	0010S	For NORMAL STOP operation, compressor will stop after it continuously unloads over this set time
	RE-START DELAY	0100S	Machine can start only over this set time at any case(after normal stop, standby or alarm &stop)
	VSD UP SPEED	0010	Restrict PID calculations in case the frequency increasing too fast which cause motor speeding up too fast
	VSD DN SPEED	0010	Restrict PID calculations in case the frequency decreasing too fast which cause motor slowing down too fast
OPERATION MODE	START MODE	LOCAL/ REMOTE	LOCAL :only the button on the controller can turn on and turn off the machine. REMOTE: both the button on the controller and the remote control button can turn on and turn off the machine;
	LOAD MODE	AUTOMATI CAL/MANU AL	MANUAL : only when the pressure is above UNLD P, compressor will unload automatically .For any other case ,the Load/Unload function can only be executed by pressing “load/unload” key. AUTOMATICAL: the load/unload function can be executed by the fluctuation of AIR P automatically
	COM MODE	DISABLE/ BLOCK/ COMPUTER	DISABLE: communication function is not activated. COMPUTER: compressor can communicate with computer or DCS as slave according to MODBUS-RTU. BLOCK: compressors can work in a net
	COM ADD	0001	Set the communication address in COMPUTER or BLOCK mode. This address is unique for every controller in net

BLOCK PARAMETER SET	BLOCK STATUS	MASTER/ SLAVE	1.When service as master in BLOCK, master controls slave; the COM ADD should be set as No.1 2.When service as slave in BLOCK, slave is controlled by master
	BLOCK ON/OFF	ORDER/ ALONG	
	TURN TIME	0002H	When master pressure is between BLOCK LOAD P and BLOCK UNLD P, master determines slave to work alternatively after working over this set time
	BLOCK NUMBER	0002	Number of air compressors in block net
	BLOCK LOAD P	00.63MPa	In BLOCK mode, one compressor will start or load when master AIR P is below this set data
	BLOCK UNLD P	00.78MPa	In BLOCK mode, one compressor will stop or unload when master AIR P is above this set data
	BLOCK DELAY	0020S	In BLOCK mode, when master sends two commands continuously, second command signal delays for this set data

CLR MAINTENANCE TIME	OIL FILTER	0000H	Record total running time of oil filter. If changing new oil filter, the data should be reset by manual operation.
	O/A SEPERATOR	0000H	Record total running time of O/A separator. If changing new O/A separator, the data should be reset by manual operation
	AIR FILTER	0000H	Record total running time of air filter .If changing new air filter, the data should be reset by manual operation
	LUBE	0000H	Record total running time of lubricant. If changing new lubricant, the data should be reset by manual operation
	GREASE	0000H	Record total running time of grease. If changing new grease, the data should be reset by manual operation
MAX LIFE TIME	OIL FILTER	2000H	1, Alarm prompt when total running time of oil filter is above the set data . 2,Set this data to “0000” , alarm function for oil filter running time is not activated
	O/A SEPERATOR	2000H	1, Alarm prompt when total running time of O/A separator is above the set data. 2,Set this data to “0000” ,alarm function for O/A separator running time is not activated
	AIR FILTER	2000H	1, Alarm prompt when total running time of air filter is above the set data. 2,Set this data to “0000” , alarm function for air filter running time is not activated
	LUBE	2000H	1, Alarm prompt when total running time of lubricant is above the set data. 2, Set this data to “0000”, alarm function for lubricant running time is not activated.
	GREASE	2000H	1, Alarm prompt when total running time of grease is above the set data. 2,Set this data to “0” , alarm function for grease running time is not activated
LANGUAGE	CHINESE/ ENGLISH	ENGLISH	ENGLISH: Displays in English CHINESE: Displays in Chinese
PHASE PRO		ENABLE/ DISABLE	Enable: PHASE PRO function is activated Disable: PHASE PRO function is not activated
NEW USER PASSWORD	****	****	User could modify the user password by old user password or factory password

1.2.4,Factory Parameter

The view and modification of factory parameter requires a factory password, The modification step is same as customer parameter modification. Main function is as below:

PARAMETER	Initial Data	Function
MOTOR RATED CURR	Maximum motor overload data /1.2	When the current of motor is more than 1.2 times of the set data , the unit will stop for overload feature. (see table2.1.1)
FAN RATED CURR	Maximum fan overload data/1.2	When the current of fan is more than 1.2 times than the set data , the unit will stop for overload feature.
ALARM DISC T	105℃	When discharge temperature reaches this set data, compressor will alarm
STOP DISC T	110℃	When the discharge temperature reaches this set data, compressor will alarm and stop
STOP AIR P	00.90MPa	When pressure reaches this set data ,compressor will

		alarm and stop
UNLD P LIM	0.85MPa	This data is the maximum of UNLD P. The UNLD P in the customer parameter must be set no higher than this data.
TOTAL LOAD TIME	000095 H	Modify the TOTAL LOAD TIME
TOTAL RUN TIME	000100 H	Modify the TOTAL RUN TIME
FAULT RECORD RESET	****	Input"8888"and press "set" button to clear all the history fault record.
CURR UNBALANCE	0006	When MAX -MIN CURRENT \geq (1+ SET DATA*MIN CURRENT/10) ,the unbalance protection is activated ,compressor will alarm and stop, reporting MOTOR CURR UNBAL If the set data \geq 15, the unbalance protection will not be activated.
OPEN PHASE PROT	002.0S	If OPEN PHASE protection \geq 20 seconds, OPEN PHASE protection is not activated
INVERTER MODEL	ATV61/ATV31/7200GS SINE303/V5-H/CIMR-F7B/ SHF/MD320/SB60/SB61/ LB60G/POWTRAIN/HOLP/ MEGMEET/ACS550 、 510/MM440	Set inverter model.Controller will read inverter running parameter based on the model set. ATV61: Schneider 61/71 inverter。 ATV31: Schneider 31 inverter。 7200GS: TECO 7200GS inverter。 SINE303: CINEE inverter。 V5-H: V&T inverter。 CIMR-F7B: YASKAWA inverter。 MD320: Henschman inverter。 SHF: SANKEN inverter SB60/SB61: SENLAN inverter LB60G: LEEPER inverter POWTRAIN: POWTRAN inverter HOLP: HOLIP inverter MEGMEET: MEGMEET inverter ACS550、510:ABB inverter MM440: Siemens 440 inverter
PROD.DATE	9999-99-99	Production date set by manufacturer
SERIAL NO.	9999999999	Serial No. set by manufacturer
MOTOR INT SCALE	00.20MPa	(PID TARGET P - INTEGRAL SCALE)< detected AIR P < (PID TARGET P + INTEGRAL SCALE) ,INTEGRAL GAIN works
MOTOR INT INITIAL	0020	When detected AIR P< (PID TARGET P -INTEGRAL SCALE) or Detected AIR P> (PID TARGET P +INTEGRAL SCALE) Integral calculation is based on this data
MOTOR PROP GAIN	0010	Track speed of PID TARGET P , the bigger the data, the faster the track; the smaller the data, the slower the track
MOTOR INT GAIN	0012	Track the speed of PID TARGET P and STEADY STATE ERROR, the bigger the data ,the faster the track and smaller the STEADY-STATE ERRORS; the smaller the data ,the slower the track and bigger the STEADY-STATE ERRORS
MOTOR DIFF GAIN	0000	Track the hysteresis system(such as temperature) ,it is not used very often and normally set as "0000"
COIL STOP T	000℃	Spare

MOTOR MIN FREQ	040.0HZ	In the process of adjustment, The minimum operating frequency when pressure is over the LOAD P pressure and not reach the UNLD P
MOTOR UNLD FREQ	0030.0HZ	Permitted operating frequency in UNLD MODE
MOTOR MAX FREQ	180.0HZ	The maximum operating frequency in loading status
RUN MODE	VSD/PF	PF: Star-delta will run VSD:inverter will run (refer to schematic diagram and operation control)
FREQ SEL	50Hz/60Hz	Choose operation power frequency.(This parameter influences the sample current value. When this data is set incorrectly, the actual current is 1.2 times different from displayed current value)
DESCEND P	00.72MPa	When set as VSD mode and AIR P is detected higher than set DESCEND P, DESCEND FREQ works.(This data is only available in MOTOR VSD or MOTOR/FAN VSD mode) Suggest: this set data = VSD P+0.02(MPa)
DESCEND FREQ	005.0HZ	In VSD mode ,when the AIR P is detected higher than the set DESCEND P ,sent the data (CONTROL FREQUENCY based on the PID OPERATING REQUENCY- SET DESCEND FREQUENCY) to inverter to avoid AIR P over PID TARGET PRESS too far which may cause the compressor loading and unloading frequently. Suggest: this set data <=Motor max frequency×1% (Hz)
MOTOR STOP MODE	SLOW/FREE	SLOW: When compressor receives stop command, INLET VALVE terminals will open and MOTOR INVERTER RUN terminal will open. The compressor will stop according to STOP DELAY set. FREE: When compressor receives stop command, Inlet valve will open. MOTOR INVERTER RUN terminal will keep closed to control inverter frequency decreasing and it will open until 1 S before STOP DELAY finishes

2, Contoller Function and Technical Parameter

- 2.1,Digital input &output: 8 points of digital input, 10 points of digital relay output
- 2.2,Analog input& output: 1 points of Pt100 temperature input, 1 points of 4~20mA pressure signal input,2 groups of three phases current input (CT provided) ;
- 2.3,Input voltage of phases: three phase 380V;
- 2.4,Controller operation power: 220V、50/60Hz、12VA (Recommond20VA);
- 2.5,Measurement :
- 2.5.1Oil temperature: $-20\sim 150^{\circ}\text{C}$; Accuracy: $\pm 1^{\circ}\text{C}$
- 2.5.2Discharge temperature: $-20\sim 150^{\circ}\text{C}$; Accuracy: $\pm 1^{\circ}\text{C}$
- 2.5.3Running time: 0~999999H
- 2.5.4Current: 0~999.9A
- 2.5.5Pressure: 0~1.60MPa Accuracy:0.01Mpa
- 2.6,Phase protection: When compressor is at stop mode and detects open phase, response time $\leq 2\text{s}$;
- 2.7,Motor protection: This controller provides open phase, unbalance and overload protection to motor and fan.

2.7.1 Open phase protection: When any phase opens, the response time equals to set time; This function is not activated when OPEN PHASE PROTECTION time is set over 20s

2.7.2 Unbalance protection: when MAX-MIN current \geq SET DATA *MIN current/10 ,respond time is 5s;

2.7.3 Protection features of overload (time unit: second), please see following table (table 2.1.1) for your reference. Multiple= I_{actual} / I_{set} , response time is shown in following table (table 2.1.1) according to overload multiples from 1.2 times and 3.0 times .

I_{actual}/I_{set} Time parameter	≥ 1.2	≥ 1.3	≥ 1.5	≥ 1.6	≥ 2.0	≥ 3.0
Response time (S)	60	48	24	8	5	1

Table 2 curve table for protection of motor

2.8, Temperature protection: when actual temperature measured is higher than temperature set; response time $\leq 2s$

2.9, Contact capacity of output relay: 250V,5A; Contact endurance :500000 times;

2.10, Current error is less than 1.0%.;

2.11,RS—485communication, one for inverter and the other for block control or external communication

3,Model and Specification

3.1, Model explanation

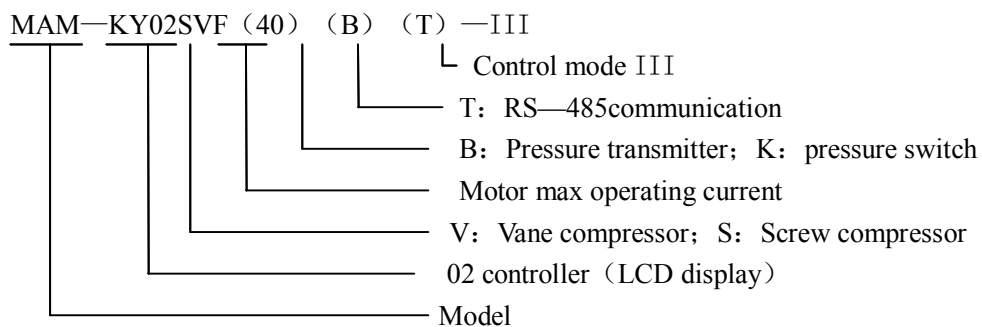

3.2, Power specification sheet for corresponding motor.

Specification	Current range (A)	Corresponding main motor power (KW)	Remark	Description
MAM—KY02SVF (20)	8~20	Below 11		Fan has three levels of current, such as 0.2-2.5A, 1-5A and 4-10A, determined by current of motor
MAM—KY02SVF (40)	16~40	11-18.5		
MAM—KY02SVF (100)	100	22-45		
MAM—KY02SVF (200)	200	55-90		
MAM—KY02SVF (400)	400	110		
MAM—KY02SVF (600/5)	600/5	200-250	With CT	

4, Inverter Communication

4.1, Communication Function

Controller can read relevant information such inverter operation frequency, output current, output voltage, motor speed and inverter fault and so on through the second RS 485 communication port A2 (485+), B2 (485-)(see detail in picture 4.1.1).In the main interface, it can display inverter operation frequency, motor power, motor speed, output voltage and so on. For more parameter, please check VSD PARAMETER in the RUN PARAMETER. To avoid communication interference, it is necessary to ground connect controller shell when controller communicates with inverter. Also, please use the cable with shielded covering to connect with controller. There will be an information to indicate if communication between controller and inverter is interrupted, in this way, please check the communication cable and the inverter parameter set.

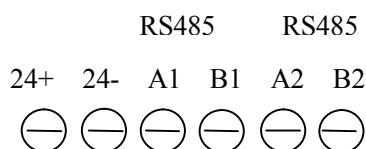

Picture 4. 1. 1

4.2, Communication Set

①、 Inverter set

When controller communicates with inverter,the Baud rate is 9600Bps,1 start bit,8 data bit,1 stop bit, No parity check bit and inverter communication address is 001.User can set relevant communication parameter through inverter menu,(See inverter communication set for detail).It is require to power off and reset after communication parameter is set

Note: To avoid communication interference, it is necessary to ground connect controller shell when controller communicates with inverter

②、 Controller Set

Set the INVERTER NAME in FACTORY PARAMETER(Different inverter share different data address register. Controller read inverter RUN PARAMETER through the INVERTER NAME set here).After set,enter USER PARAMETER and set RATED POWER and SPEED at 50HZ. based on this set ,calculate the actual power and speed for user reference.

4. 3, Inverter Upgrade Explanation

①This software edition adapts to all inverter supporting MODBUS RTU (Inverter has to read output current, output voltage, output frequency and output power)

②Controller supports 38 different inverters communication protocol. Beyond these models, you can also set the communication parameter according to below step:

- Enter FACTORY PARAMETER, move down cursor to INVERTER NAME and set it as SELF-DEF
- Return to the main menu, move the cursor to FACTORY PARAMETER, and press password 2688 to enter INVERTER SET like picture below.

VOLT	ADDRESS: FFFF
CURR	ADDRESS: FFFF
FREQ	ADDRESS: FFFF
POWR	ADDRESS: FFFF

Set the voltage address .hexadecimal

In this menu, please set the MODBUS address of output voltage, output current, output frequency and output power. After set, move down to check data calculation menu like below picture.

$V=REC*FFFF \div FFFF$ $I=REC*FFFF \div FFFF$ $F=REC*FFFF \div FFFF$	Use percentage power ,please select SET, Use real power, please select 1
$P=REC*SET/1 *FFFF \div FFFF$ COM FORM: 8N1-NONE VSD ADD: 0001	Set the data format to communicate with inverter
	Set communication MODBUS address

Example:

A customer wants to use SB70 inverter, SB70 communication protocol is not set in the inverter yet and the information in the inverter manual is as below

- Output current address: 1202H, digits 0.01A
- Output voltage address: 1204H, digits 0.1V
- Output frequency address: 1200H, digits 0.01HZ
- Output power address: 1208H, digits 0.1KW

To communicate with SB70, please set as below:

Factory parameter

FAULT RECORD RESET: 9999	Set: SELF-DEFF
CURR UNBALANCE: 0008	
OPEN PHASE PROT: 00.30S	
INVERTER NAME: SELF-DEFF	

- Return to the main menu, move the cursor to FACTORY PARAMETER, and press password 2688 to enter INVERTER SET like picture below.

VOLT	ADDRESS: 1204	Refer to the inverter manual, and set voltage MODBUS register address
CURR	ADDRESS: 1202	
FREQ	ADDRESS: 1200	
POWR	ADDRESS: 1208	

After read voltage successfully, the voltage will transfer to a one digit number

$V=REC*0001 \div 0001$
 $I=REC*0001 \div 0010$
 $F=REC*0001 \div 0010$

After read frequency successfully, the frequency will transfer to a one digit number. SB70 frequency is with two digits, to transfer to one digits, it should be divided by 10

$P=REC*1*0001 \div 0001$
 COM FORM: 8N1-NONE
 VSD ADD: 0001

SB70 support MODBUS RTU protocol, the data format can set as: 8N1no parity bit

5, Installation

5.1, Mechanical Installation

5.1.1, CT Installation

The CT shall be installed at a place where the current of motor cable can be measured, thus, controller can be set according to instructions on motor nameplate, and the detailed dimension is shown as below:

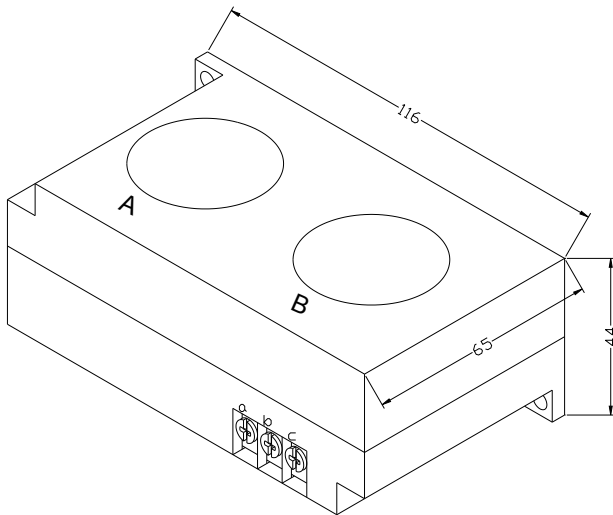

Picture1、CT1 Structural dimension of CT1 (φ36 hole)

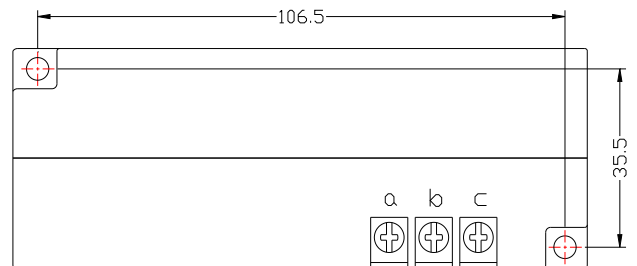

Picture2、CT1 Installation dimension

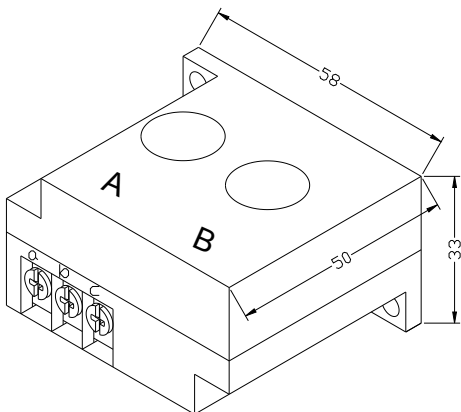

Picture 3、Structural dimension of CT2 (φ10 hole)

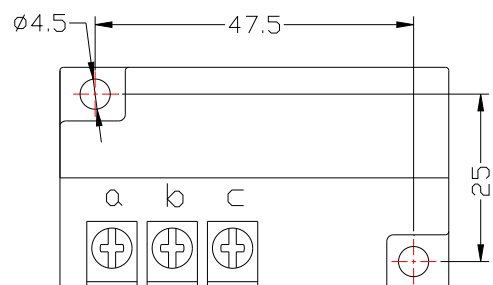

Picture 4、CT2 Installation dimension

5.1.2, Controller Installation

When install the controller, room should be left around controller for wiring. The specific dimension is shown as below:

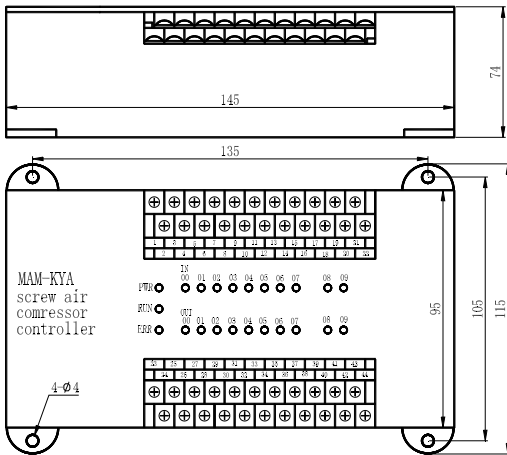

1、Indicator (IN):

The corresponding digital input terminal of 00、 01、 02、 03、 04、 05、 06、 07 is 20、 19、 18、 17、 16、 15、 14、 13.

2、Indicator (OUT)

The corresponding digital input terminal of 00、 01、 02、 03、 04、 05、 06、 07、 08、 09 is 27、 28、 29、 30、 31、 35、 36、 37、 38、 39

3、 Power Indicator: PWR

4、 Run indicator: RUN

5、 Error indicator: ERR

Picture 5、 Controller structure dimension

5.1.3, Panel Function and Installation Panel Structure 165×102×50 (mm)

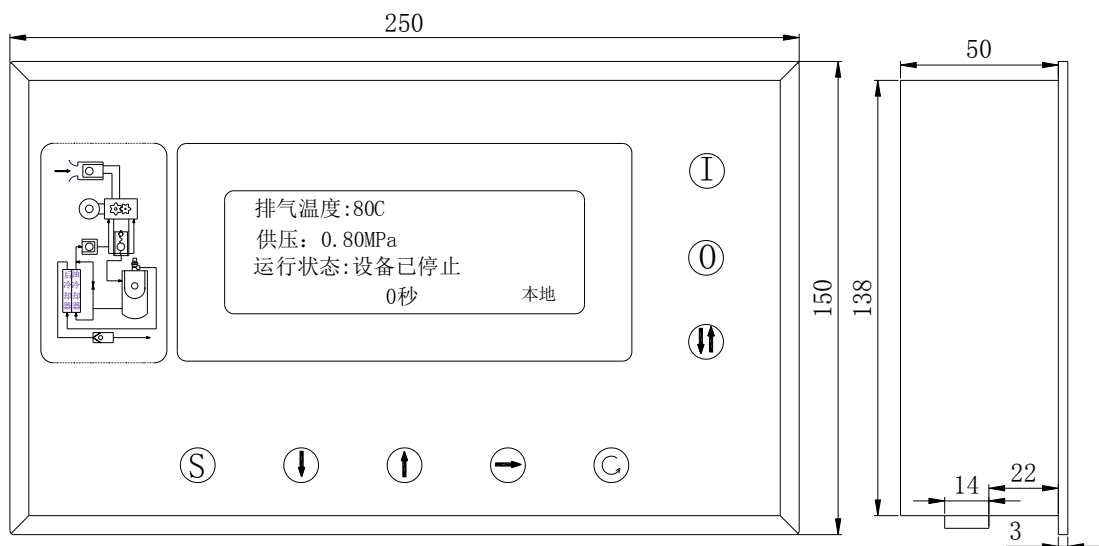

Picture 6, Panel Dimension

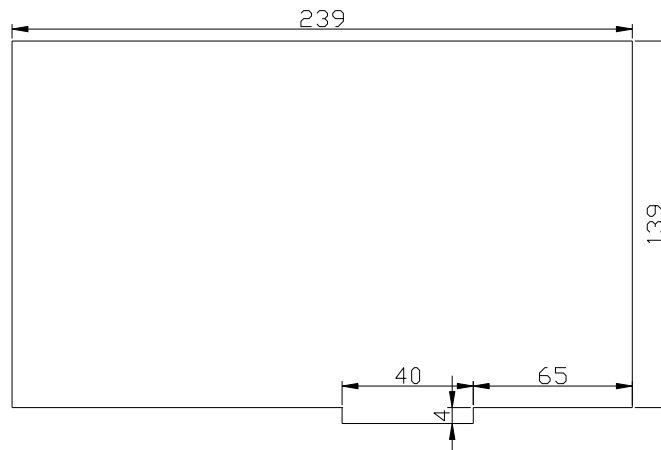

Picture 7, Hole dimension

5.2, Electrical Connections

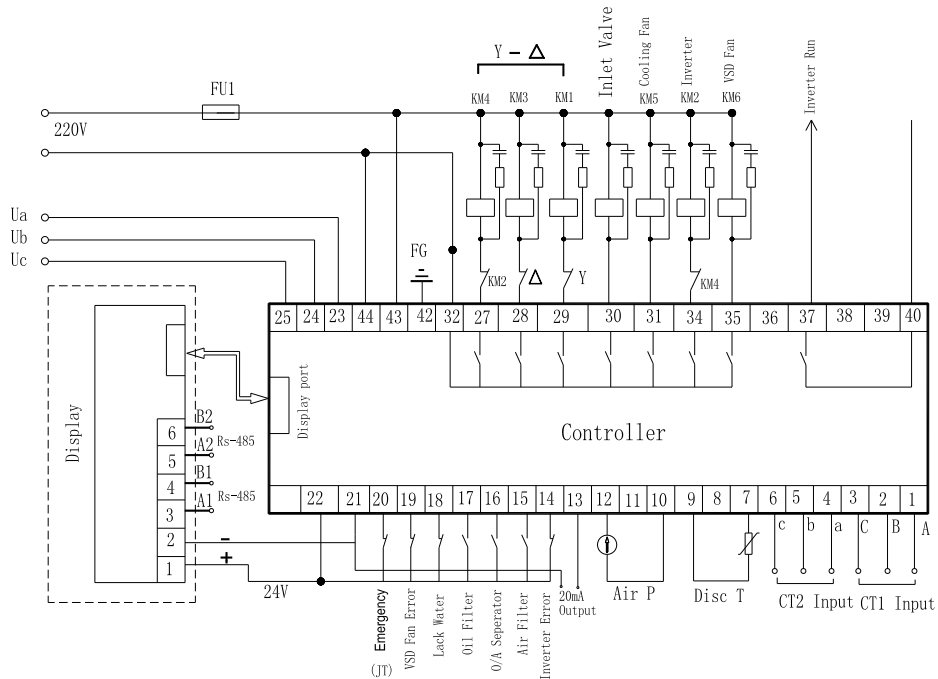

Picture 8、 Terminal arrangement diagram

Monitor connection terminal:

There are five connection cables and a communication cable which are used for display connection , RS-485 communication ,24V power supply.

Controller connection terminal:

Communication cable is used to connect monitor and controller

1.2.3	CT1:Motor current transformer	4.5.6	CT2:Fan current transformer	7、 9	Discharge temperature input
23、 24、 25	Phase input	27	Motor contactor (PF)	28	Star contactor (PF)
29	Delta contactor	30	Inlet valve	31	Fan
32	Output relay COM1	34	Control inverter(VSD)	35	Control VSD Fan
37	Run indicator	38	Error indicator	39	Alarm indicator
40	Communication port 2	42	GND(analog)	43,44	220V

* Note : Electromagnetism coil shall be connected nearest with RC snubber during wiring, Dotted line is for extra function

6, Alarm Function

6.1、 Monitor Indication

6.1.1, Air Filter Alarm

- ①. Air filter block check.

The monitor displays AIR BLOCK by checking pressure differential switch close.

②. Air filter running time alarm

The text displays AIR TIME END when running time of the air filter is exhausted.

6.1.2, Oil Filter Alarm

①. Oil filter block check.

The monitor displays OIL BLOCK by checking pressure differential switch close.

②. Oil filter running time alarm

The text displays OILTIME END when running time of the oil filter is exhausted.

6.1.3, O/A Separator Alarm

①. O/A separator block check.

The monitor displays O/A BLOCK by checking pressure differential switch close.

②. O/A filter running time alarm

The text displays O/A TIME END when running time of the oil filter is exhausted.

6.1.4, Lubricant Alarm

The text displays LUBE TIME END when running time of the lubricant is exhausted.

6.1.5, Grease Alarm

The text displays GREASE TIME END when running time of the grease is exhausted.

6.1.6, Discharge Temperature High Alarm

The text displays DISC T HIGH when DISC T is higher than ALARM DISC T set in FACTORY PARAMETER.

6.2, Controller indicator

Indicator	Meaning and function	Indicator status
Power	Controller power on	PWR indicator on
Run	Controller run	RUN indicator on
Error	Failure and stop	ERR indicator blink
Digital input	Terminal 26~18 digital input	IN00~08 corresponding indicator on. Indicator will not be illuminated if input has no function
Digital output	Terminal 39、40、41、42、43、46、47、49、50、51 digital output	OUT00~09 corresponding indicator on
Data storage	Data and time set	PWR blink once

7, Controller Protection

7.1, Motor protection

MAM—KY02SVF compressor controller provide short circuit ,block, overload, lack phase, unbalance protection to motor.

Electronic failure	Failure display	Reason
Short circuit	Display “Motor/FAN OVER LOAD”	Short circuit or wrong current set
Current Block	Display “Motor/FAN BLOCK”	Overload, bearing wear and other mechanical failure
Overload	Display “Motor/FAN OVERLOAD”	Overload, bearing wear and other mechanical failure
Lack phase	Display “Motor/FAN *LACK PHASE”	Power supply, contactor and open phase of motor
Unbalance	Display “Motor/FAN UNBALANCE”	Poor contact of contactor, inside open-loop of motor

7.2, Protection of Discharge Temperature High

When DISC T is above the STOP DISC T, the controller will alarm and stop the machine. THIS FAULT displays DISC T HIGH

7.3, Protection of Air Compressor anti-reversal

When compressor is at stop status and three phases sequence is not in order, THIS FAULT displays PHASE WRONG1, and the controller cannot start the motor. Change the position of any arbitrary two phase power lines and check the rotation of motor.

7.4, Protection of Air Pressure High

When the AIR P is above the MAX LIM P, the controller will alarm and stop the machine. THIS FAULT displays HIGH P.

7.5, Protection of Sensor Fault

When pressure sensor or temperature sensor is disconnected, the controller will alarm and stop the machine. THIS FAULT displays **SENSOR FAULT.

7.6, Protection of Air Compressor Open Phase

When compressor is at stop status and open phase is detected, THIS FAULT displays PHASE WRONG2, and the controller cannot start the compressor. Check the three phase.

7.7, Protection of VSD Fan

When VSD fan is failure, controller will stop

7.8, Protection of Inverter

When inverter is failure, controller will stop

8, Troubleshooting

8.1、 This Fault Review

Alarm and stop caused by the external parts of controllers may be removed by checking THIS FAULT or FAULT RECORD, method is shown as below:

Press“↓” to move the cursor to “RUN PARAMETER” menu, then press“→”,the secondary menu will show as below:

```

MOTOR FAN CURR
VSD PARA
TOTAL RUN TIME
THIS RUN TIME
    
```



```

MAINTENANCE PARAMETER
FAULT RECORD
PROD.DATE、 SERIAL
THIS FAULT
    
```

Move the cursor to “THIS FAULT” menu Then press“→”to switch to the following menu (display failure) :

```

STOP: DISC T SENSOR
FAULT
170℃
    
```

User can reset fault according to the information prompted

8.2、 Common Failures and Causes:

Failure	Reason	Solution
High discharge temperature	Bad vent condition, Oil shortage etc.	Check the vent condition and lubricant amount etc.
Temperature Sensor Failure	Cable broken or PT100 failure	Check the wiring and PT100
High Pressure	Pressure too high or the pressure sensor failure	Check the pressure and the pressure sensor
Pressure Sensor Failure	Cable broken, Sensor failure or the cables connect reversely	Check the wiring and pressure transmitter
Lack water	Water pressure switch failure	Check water pressure switch
Open Phase	Power open phase or the contactor failure	Check the power and contactors
Overload	Voltage too low, tubes block, bearing wear off or other mechanical failure or wrong set data etc.	Check the set data, voltage, bearings, tubes and other mechanical system.

Unbalance	Current unbalance, contactor failure or the internal open loop of the motor	Check the power, contactor and the motor
Wrong Phase Sequence	Phase sequence reversal or open phase	Check the wiring
Fan fail to run	Fan failure, contactor failure, no control output	Check wiring
Motor overload during start	Master start time set to less than the star delta delay time	Reset the master start time longer than star delay + 2 seconds
Main Contactor shakes frequently	The emergency stop button is loose or controller is reset by interference	Check if the coil of contactor connects with RC snubber or not

9, Schematic Diagram:

