

Schematic Diagram

01 PF

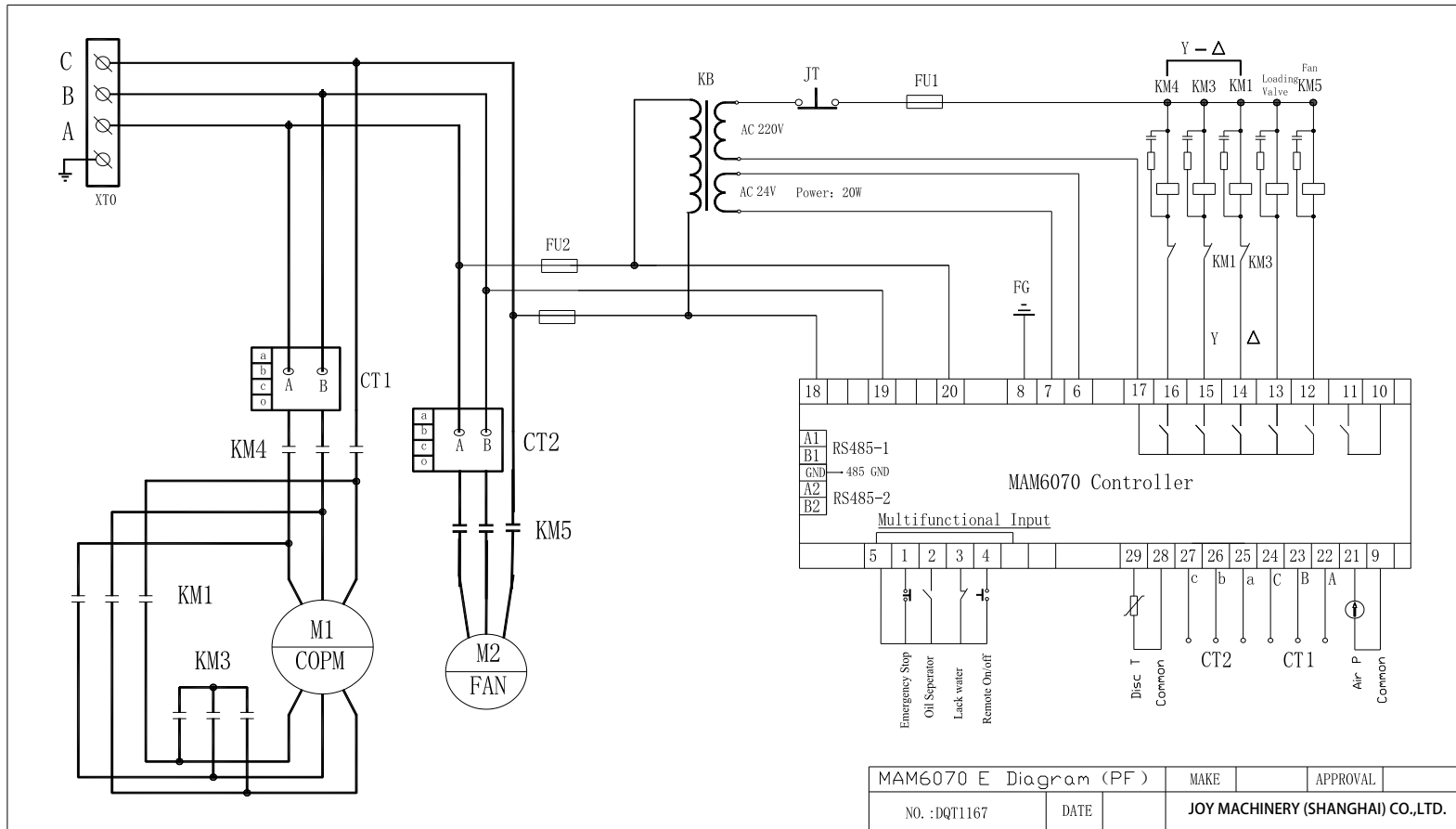

Joy Machinery (Shanghai) Co., Ltd Type: MAM6070 V.1

02 PM/MOTOR VSD

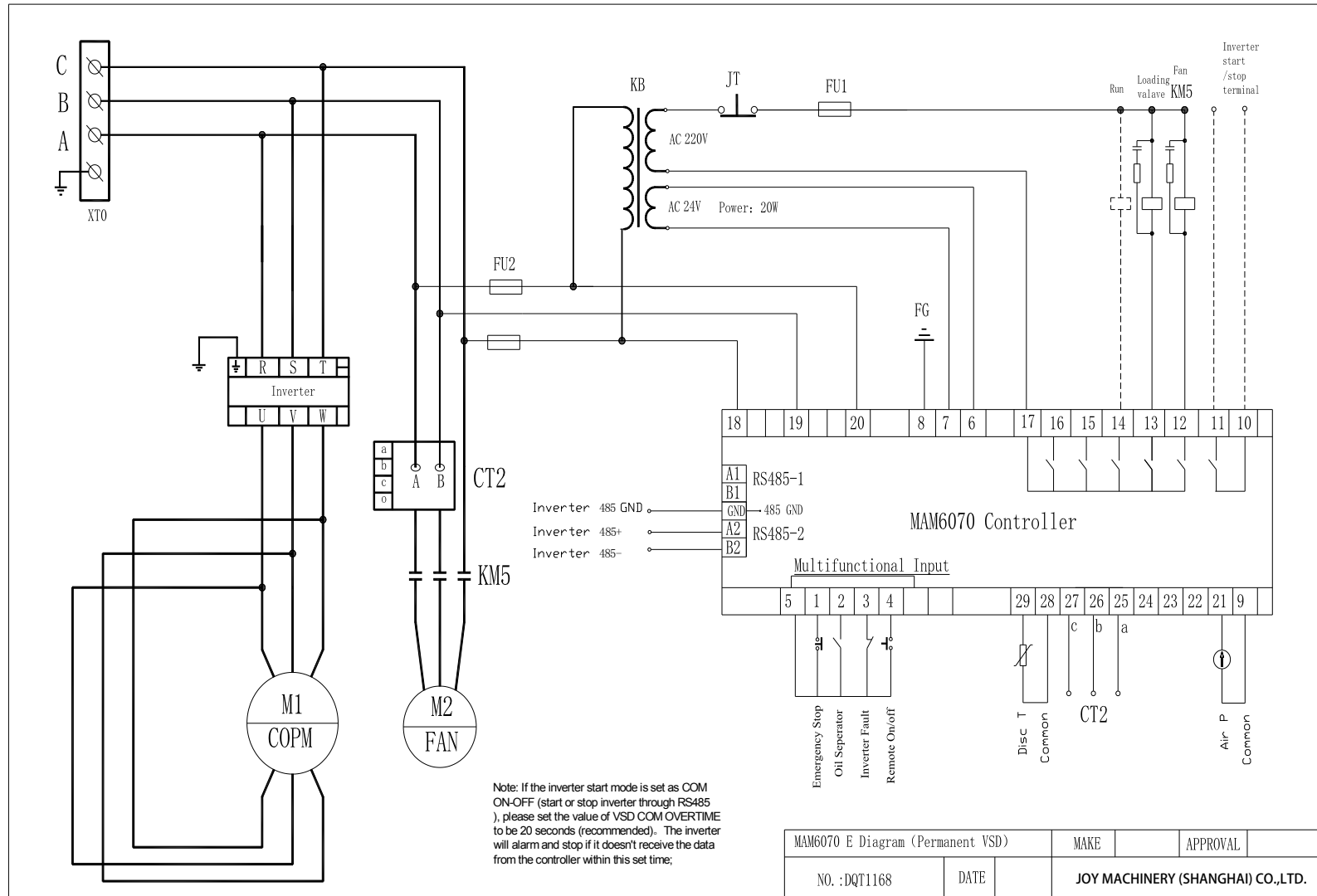

03 PF/VSD

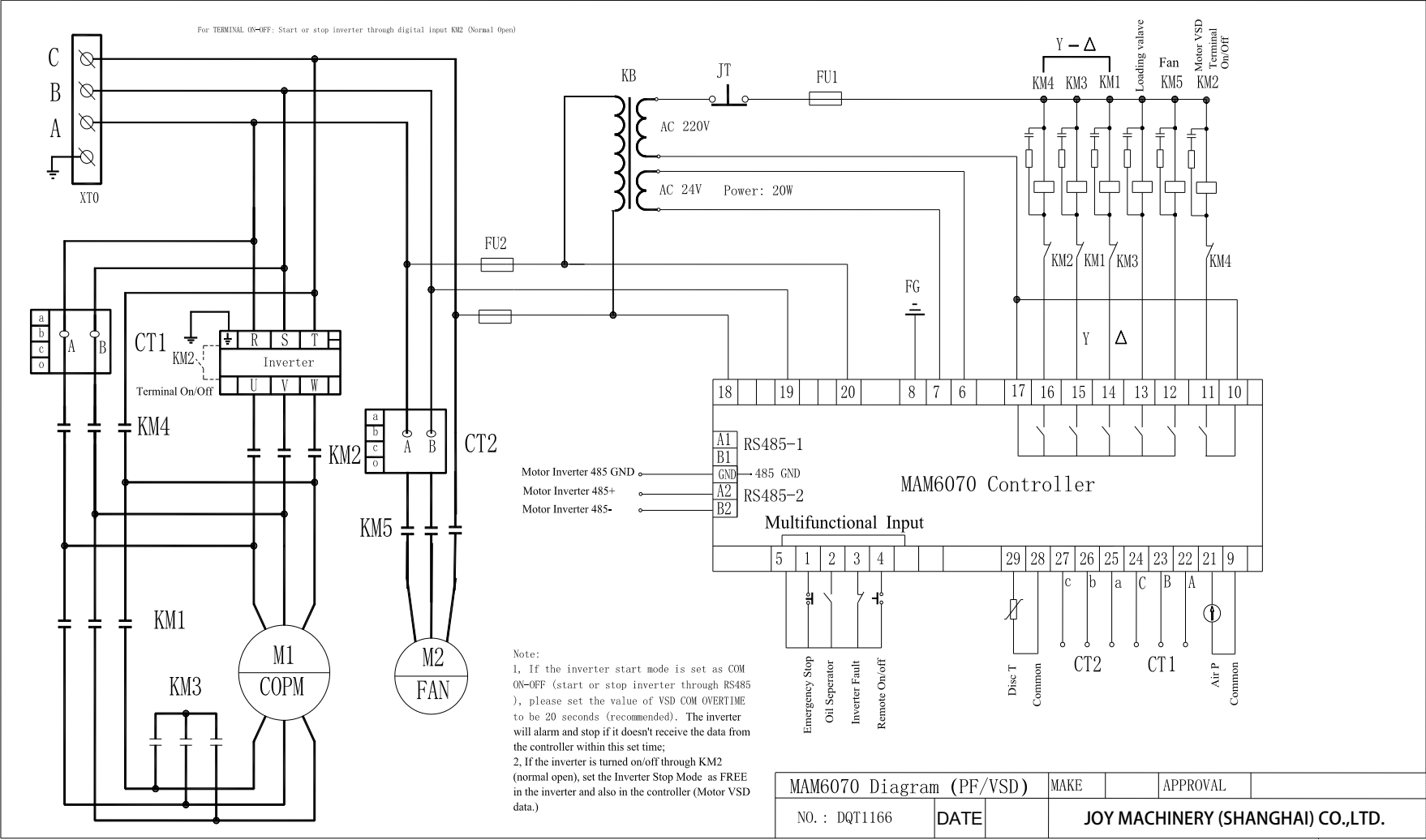

04 FAN VSD

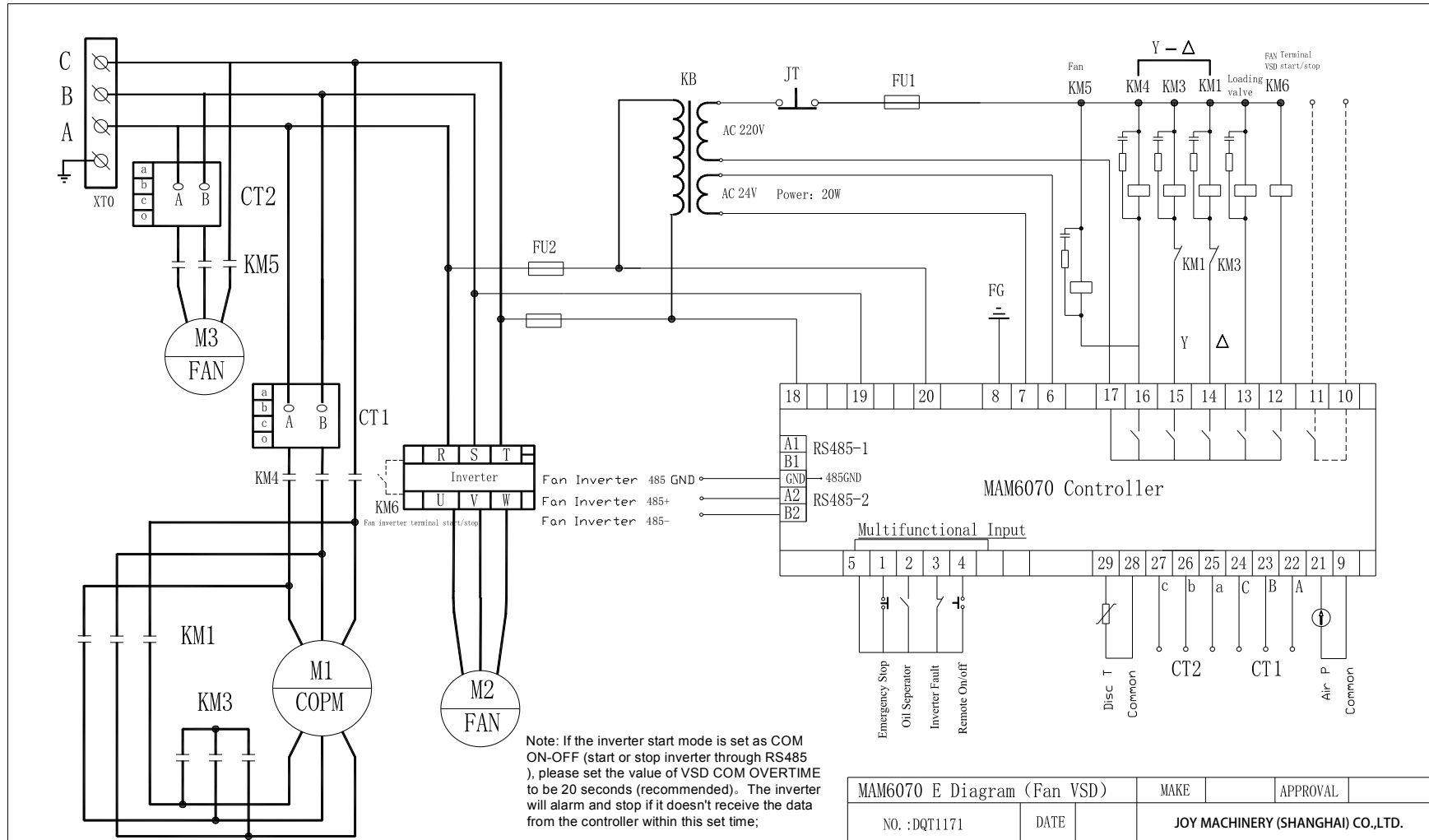

05 MOTOR/FAN VSD

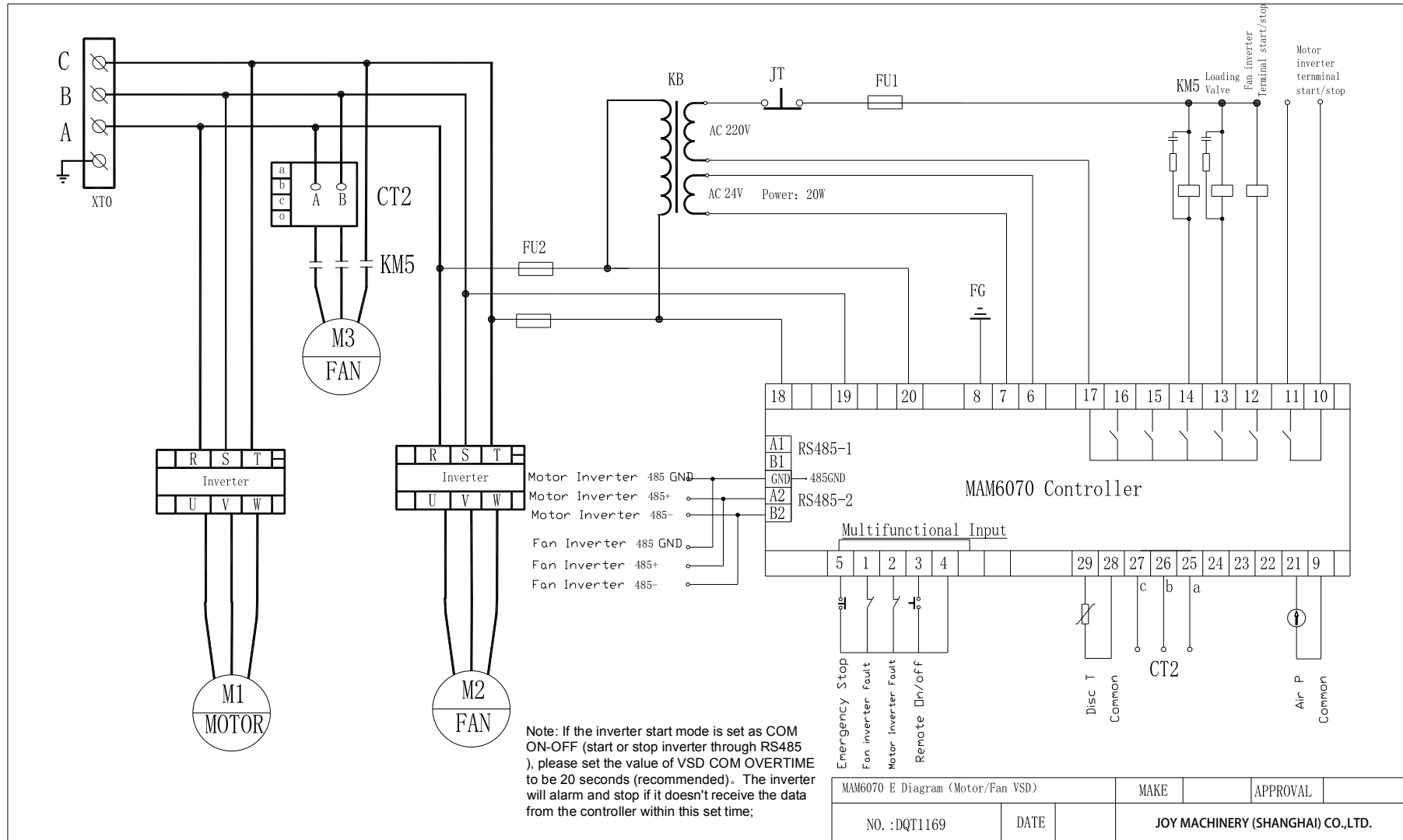

06 SOFT START

